

6630-50

Angle de pas
Schrittwinkel
Step angle 1.8 °

Diamètre
Durchmesser
Diameter 86 mm

Poids
Gewicht
Weight 4000 g

Couple de retenue
Haltemoment
Holding torque 10 Nm

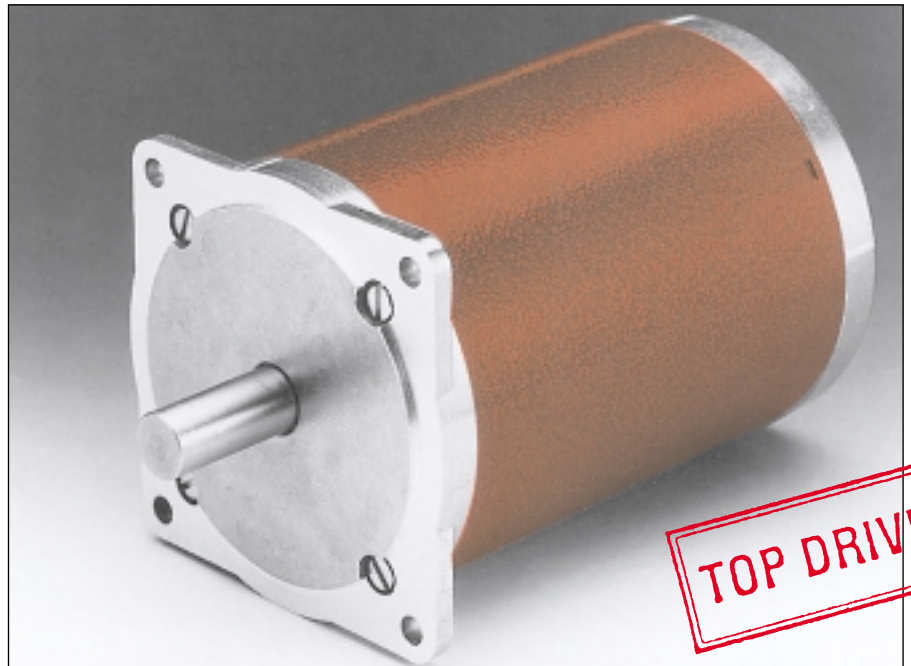

		Résistance de phase Phasenwiderstand Phase resistance Ω	Induct. de phase Phaseninduktivität Phase inductance mH	Courant de phase Phasenstrom Phase current A	Couple de retenue Haltemoment Holding torque Nm	Puissance nominale Nennleistung Nominal power W	<ul style="list-style-type: none"> U_1 1 vert / grün / green 2 orange / orange / orange U_2 3 noir-blanc / schwarz-weiss / black-white 4 vert-blanc / grün-weiss / green-white U_3 5 rouge / rot / red 6 noir / schwarz / black U_4 7 blanc / weiss / white 8 rouge-blanc / rot-weiss / red-white
6630-50-4-0.4	Phases en parallèle Phasen parallel Phases in parallel	0.2	1.8	10	10	40	
	Phases en série Phasen in Reihe Phases in series	0.8	7.2	5	10	40	

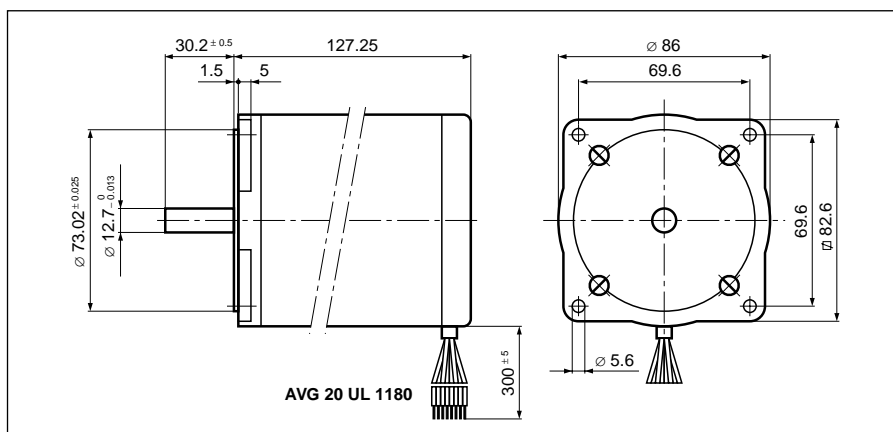

Pas/ Schritte/U Steps/rev	200
Précision/pas Schrittgenauigkeit Step accuracy	± 5 %
Inertie du rotor Rotorträgheitsmoment Rotor inertia	3950 gcm²
Classe d'isolation Isolationsklasse Insulation class	B 130 °C
Protection Schutzart Protection	DIN 40050 IP 30
Tension d'essai Prüfspannung Test voltage	500 VAC
Couple résiduel Restmoment Detent torque	340 mNm

Caractéristiques dynamiques
Dynamische Daten
Dynamic characteristics

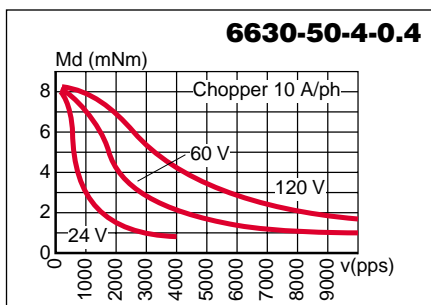

Phases en parallèle
 Phasen parallel
 Phases in parallel

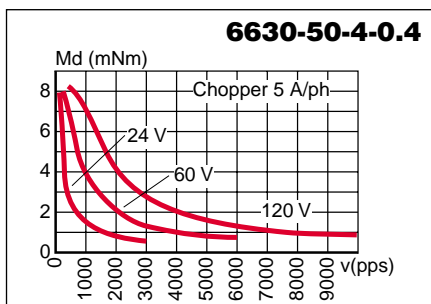

Phases en série
 Phasen in Reihe
 Phases in series

Caractéristiques statiques
Statische Daten
Static characteristics

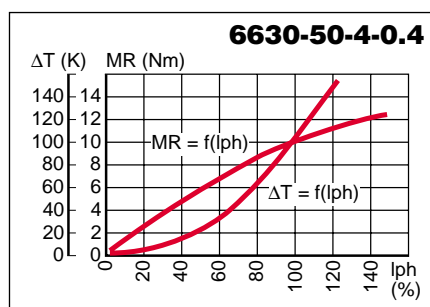

Possibilités d'exécutions adaptées sur demande.
 Auf Wunsch werden kundenspezifische Anforderungen berücksichtigt.
 Special requirements can be made to customer specification.

SONCEBOZ SA
 CH-2605 Sonceboz
 Tél: +41 32 488 11 11
 Fax: +41 32 488 11 00
 E-Mail: info@sonceboz.com
 Internet: www.sonceboz.com

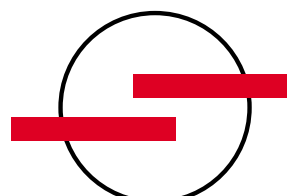

SONCEBOZ
 The driving force